



Three-Phase Asynchronous Motor User Manual

JIE Total Drive Solutions Provider

www.jie-drives.com

Catalog

1. Important Notices.....	4
2. Safety Precautions.....	5
3. Motor Structure.....	6
3.1. Exploded View of Motor Components.....	6
3.2. Nameplate and Model Description.....	7
4. Motor Installation.....	8
4.1. Precautions Before Installation.....	8
4.2. Preparation Work.....	8
4.3. Installing the Motor.....	9
5. Electrical Installation.....	10
5.1. Wiring Tips.....	10
5.2. Considerations During Variable Frequency Drive (VFD) Operation.....	10
5.3. Environmental Conditions During Operation.....	10
5.4. Motor Connection.....	11
5.4.1. Connecting the Motor via Junction Box.....	11
5.6. Wiring Method - Single-Speed Motor.....	13
5.7. Wiring Method - Two-Speed Motor.....	14
5.7.1. Independent Two-Speed (8/2 poles).....	14
5.7.2. Variable-Pole Two-Speed-Wiring bridge installation for low-speed operation.....	14
5.8. Wiring Method - Independent Fan.....	15
5.8.1. Single-Phase Asynchronous Independent Fan.....	15
5.8.2. Three-Phase Asynchronous Independent Fan.....	15
5.9. Wiring Method - Brake.....	16
5.9.1. Motor Voltage 220□V, 380YV Corresponding to Brake Voltage 220V and 380V Wiring.....	16
5.9.3. Variable-Pole, Variable-Frequency Motor Brake Wiring.....	17
5.9.4. Connecting the Brake.....	17
5.10. Auxiliary Equipment.....	18
5.10.1. Temperature Sensor TF.....	18
5.10.2. Coil Thermostat TH.....	18
5.10.3. Temperature Sensor PT100.....	18
6. Brake Installation and Usage Instructions.....	19
6.1. Structure.....	19
6.2. Installation Instructions.....	19
6.3. Adjustment of Air Gap.....	19
6.4. Brake Maintenance.....	20

7. Debugging.....	21
7.1. Prerequisites for Debugging.....	21
7.1.1. Before Putting into Operation.....	21
7.1.2. During the Debugging Operation.....	21
8. Inspection and Maintenance.....	22
8.1. Inspection and Maintenance Cycle.....	23
8.3. Motor Inspection Operation Steps.....	24
9. Operation failure:.....	25
9.1. Motor Malfunctions.....	25
9.3. Customer Service.....	27

1. Important Notices

The manual contains important instructions for operation and maintenance.
This manual is primarily intended for all personnel engaged in equipment assembly, installation, debugging, and maintenance.

Safety Tips and Warning Alerts

Please note of the safety and warning instructions provided in this user manual.



Electric Shock Hazard
Potential consequences: May lead to death or serious injury.



Contact Hazard
Possible consequences: Death or serious injury.



Dangerous Position.
Possible consequences: Minor injury.



Damage Position
Possible consequences: Damage to transmission devices and the environment.



High-Temperature Danger
Possible consequences: Burn or scald hazard.



All provisions in this instruction manual must be strictly followed to ensure proper operation of the product and satisfy any quality assurance requirements. Therefore, please read the instruction manual carefully before operating the motor. As this instruction book contains vital operation information, it should be kept near the motor or easily accessible.



Proper waste disposal:

Waste disposal of motors should be carried out according to local, state, and federal guidelines relating to:

- Scrap iron, aluminum, and copper recycling
- Plastic waste disposal or recycling
- Electronic components recycling

2. Safety Precautions

Foreword

The following safety tips primarily concern the use of the motor. When using the motor, pay attention to the installation tips in the manual.

Also, refer to the supplementary safety tips in each chapter of this operation manual.

Overview

During and after operation, the motor may have moving components, and the surface may retain heat even after operation has ceased. All operations related to transportation, warehousing, installation/assembly, wiring, debugging, maintenance, and upkeep must be carried out by trained professionals. Pay close attention to:

- Detailed operating instructions and circuit diagrams
- Motor warnings and safety signs
- Specific equipment regulations and requirements
- Local, state, and federal regulations on safety and accident prevention

The following situations may lead to serious personal injury and material loss:

- Incorrect use
- Installation or operational errors
- Unauthorized removal of necessary protective covers or guards

Use According to Regulations

These motors are designated for industrial equipment and comply with current standards and regulations, including GB/T12350 for the safety requirements of low-power motors.

Transportation/Storage

Upon receiving goods, promptly inspect them. If damage occurred during transport, usage must be prohibited, and the transportation company should be immediately notified. Ensure the eyebolt screws are tightly secured before lifting. Do not lift the motor with any additional weight as the eyebolt screws have a rated load to lift the motor only. Use only approved and adequate load-bearing installation tools. Before commissioning the motor, remove the existing transportation fasteners.

Installation/Assembly

Ensure the equipment is placed steadily, fix anchor and flange securely, and precisely calibrate directly connected couplings to prevent improper installation causing resonance in rotation frequency and double power supply frequency. Turn the rotor by hand, checking for abnormal friction noise. Ensure the motor spins in the proper direction with the external equipment connected.

Use only appropriate tools to install or dismantle pulleys or couplings (preheat!) and isolate using contact protection devices to avoid unauthorized belt tension. Complete necessary piping connections. Motor models with the shaft end up require installers to assemble a protective cover to prevent foreign objects from entering the fan. Ensure unrestricted ventilation and prevent the re-inhalation of exhausted hot air, including from nearby equipment. Adhere to the tips in the "Motor Installation" chapter.

For more information, see installation tips in the "Motor Installation" chapter.

Start/Run

Check that the rotation direction is correct in the free state (while monitoring for abnormal sounds during shaft rotation). During operation checks, ensure there are no output components on the shaft key, and activate relevant monitoring and protection equipment.

If there is any suspicion of abnormal operation (e.g., temperature rise, noise, vibration), immediately cut off the motor power supply and investigate the cause. Contact JIE if necessary.

3. Motor Structure

The following illustrations depict the motor construction and serve as a guide for parts classification. Different parts may be present for motors with varying frame numbers or design structures.

3.1. Construction Principles of Flow Motor

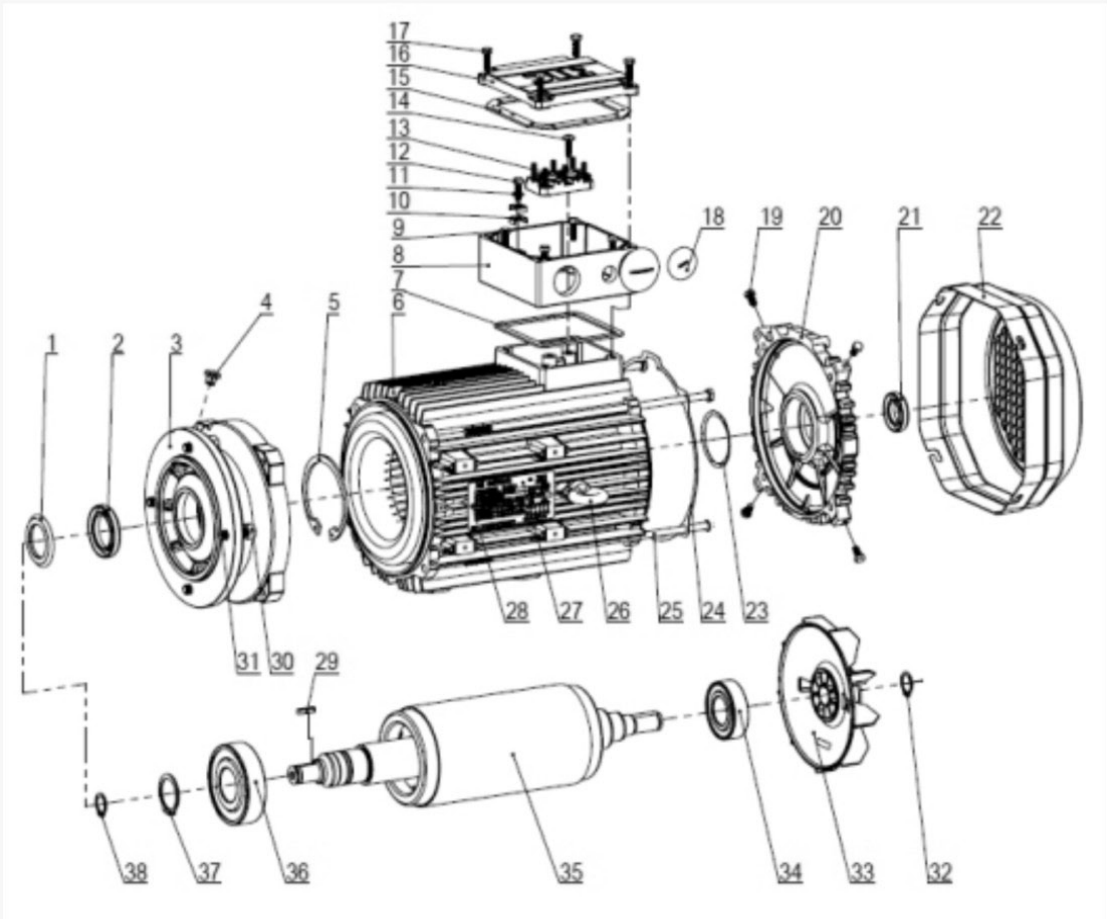



- | | | | |
|-----------------------|------------------------|---------------------|-------------|
| [1]Oil ring | [11]Washer | [21]Oil seal | [31]Studs |
| [2]Oil seal | [12]Bolt | [22]Fan cowl | [32]Circlip |
| [3] A Flange end caps | [13]Terminal board | [23]Wave washer | [33]Fan |
| [4]Screw plugs | [14]Screw | [24]Gasket | [34]Bearing |
| [5]Circlip | [15]Gasket | [25]Bolt | [35]Rotor |
| [6]Stator | [16]Terminal box base | [26]Rings | [36]Bearing |
| [7]Gasket | [17]Bolt | [27]Motor nameplate | [37]Circlip |
| [8]Terminal box base | [18] Hole cover | [28]rivet | [38]Circlip |
| [9]Screw | [19]Bolt | [29]Key | |
| [10]Ground cord | [20]B Flange endshield | [30]nut | |

3.2.Nameplate and Model Description

3.2.1. nameplate

example: Motor DN90L4

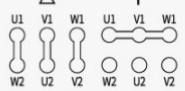
	THREE PHASE INDUCTION MOTOR IEC60034			DUTY S1		
	Type	DN90L4/P/D200/XXX		IM	B5	
	NO.	1002080810001		50	Hz	
		220	Δ/	380	V	η% 85.3
		1.5	kW	6.3/3.8	A	IP 55
		1450	r/min	COSΦ		POD 20XX.XX
	V _B	V		CI		
	T _B	Nm		24	kg	

HANG ZHOU JIE DRIVE TECHNOLOGY CO.,LTD.

3.2.2 JD Model Description

JD
N
90L
4
/
P
/
D200
/
BE/TF/TH/C/V/EV/STH

1
2
3
4
5
6
7

1 JIE code J:JIE D:THREE-PHASE INDUCTION MOTOR	2 Energy efficiency index S:No energy Efficiency IE2 N/E:Energy efficiency level 3 IE3 U : 2 Energy efficiency level 2 IE4 H:Energy efficiency level 1 IE5 Note:Energy efficiency compliant GB18613-2020、IEC60034-30	3: Frame sizes 63、71、80、90、 100、112、132、 160、180、200、 225、250、280 etc. S:Short iron core M:middle iron core L:long iron core	4:Poles 2、4、6、 8、 4/2、 6/4 etc.	5: Mounting positions P:Geared Motors IEC: IEC Motors NEMA: NEMA Motors
7:Motor option code (in no particular order) BE:Brake C:Protection cowl HR: Handle release STH:Electric Heating HF:Screw releaseTF:Temperature sensor TH:Thermostat protection device 2WE:Rearshaft of the motor V:Forced cooling fan			6:Installation method D: Mounting flange diameter 200: The size of the flange is200 IEC Motors: B3、B5、B14... NEMA Motors: 56C、143TC、184TC...	
The following customized attachments are available to our company: Encoder(Solid shaft) /EV Backstop/RS Encoder (Hollow shaft)/ES Non-ventilated(No fan)/U Additional flywheel/Z Reinforced insulation/RI				

 <p>The nameplate and model description comply with the regulations of the People's</p>	 <p>Republic of China for small equipment. It is used to confirm UL (Underwriters Laboratory) validation of registered components and meets European standards</p>	 <p>such as low-pressure standards.</p>
--	---	--

4. Motor Installation

4.1. Precautions Before Installation

Motor installation is permissible under the following conditions:

- The voltage on the nameplate of the drive matches the power supply system voltage or the output voltage of the frequency inverter.
- The drive device is undamaged (not damaged during transportation or storage).
- The following conditions are confirmed:
 1. Ambient temperature is between -20°C and +40°C;
 2. Absence of oil, acid, gas, steam, radiation, etc.;
 3. The installation location's highest altitude is 1000 meters;
 4. Special specifications: The drive device is designed based on environmental conditions.

4.2. Preparation Work

It is imperative to thoroughly clean the motor's shaft end from rust inhibitors, contaminants, or similar substances using common chemical cleaners. Ensure that cleaning agents do not infiltrate the bearings or sealing rings, as this could lead to material damage.

Long-Term Motor Storage:

After storing for more than a year, take note that the lubricant usage time for the reducer bearing may be reduced.

Check for exposure to moisture if the motor has sat in prolonged storage. It is crucial to test the motor's insulation resistance (testing voltage: 500V).

Insulation Resistance (See Diagram Below):

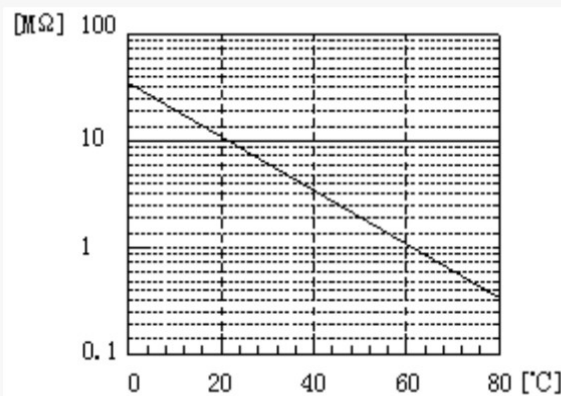

Motor Drying Procedure.

Heating the motor:

- Use hot air
 - Use a transformer
1. Connect series windings in sequence. (See wiring diagram below)
 2. Supply AC voltage up to 10% of the rated voltage and 20% of the rated current.

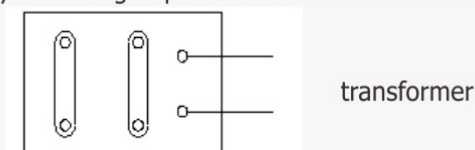

The drying process is complete when the minimum insulation resistance requirement is met. Check the junction box for internal dryness, clean connectors and fasteners, ensure seals are intact, and replace or clean cable sealing plugs if necessary.

4.3. Installing the Motor



be careful

- Install the motor only in the specified manner, on a flat, vibration-free, and distortion-resistant base.
- Carefully align the motor and driven equipment to prevent exceeding the allowable range of output shaft load (consider allowable lateral and axial forces).
- Avoid impacting or striking the shaft end.
- For vertical installations, implement shielding measures to prevent the entry of foreign objects or liquids (use rain cover C).
- Ensure efficient heat dissipation, unobstructed air ventilation, and prevent blocked discharge of hot air.
- The condensate drain hole is hermetically sealed using a plastic plug and should only be unsealed under specific requirements. It is imperative not to leave the condensate drain hole open, Doing so would render the motor casing protection ineffective.
- For brake motors with manual devices, engage the manual release lever (spring-return manual ventilation device) or tighten bolts (fixed manual ventilation device).

Humid or Outdoor Installations:

- Orient the cable inlet downward when installing the junction box.
- Apply sealant to the threads of fastening screws and blind holes; tighten, and reapply sealant. Ensure the cable inlet is thoroughly sealed.
- Before reassembly, clean the sealing surfaces of the junction box and junction box cover. Affix the gasket to one side of the sealing surface. Replace immediately if the gasket has become brittle during transport.
- Repair any damaged sections of the anti-rust layer.
- Verify the protection level.

4.4 Assembly tolerances

Shaft	Flange
End Diameter Tolerance (per EN 50347 standard)	Flange tolerances (according to EN 50347)
ISO j6 ($\Phi \leq 28\text{mm}$)	ISO j6 ($\Phi \leq 250\text{mm}$)
ISO k6 ($\Phi \geq 38\text{mm} \leq 48\text{mm}$)	ISO h6 ($\Phi \geq 300\text{mm}$)
ISO m6 ($\Phi \geq 55\text{mm}$)	
Center Hole (per DIN332 standard)	

5. Electrical Installation



The electrical connections to the motor must be based on the eprovided wiring diagram. If the diagram is missing, the motor must not be connected or started.
Contact JIE to resolve any issue of this matter.

5.1. Wiring Tips

Pay attention to safety precaustions during installation to prevent interference with the brake controller.

To prevent interference with the brake controller, the power line of the brake should not be laid in the same cable as the switch-type power line.

Switch-type power lines mainly refer to:

- Output cables of inverters, servo inverters, converters, soft start devices, and brake devices.
- Connection lines of the brake resistor.

Interference protection for motor protection devices

To prevent interference with JIE motor protection devices (temperature sensor TF, thermostat switch TH):

- Only shielded power lines can be laid in the same cable as the switch-type power lines.
- Unshielded power lines should not be laid in the same cable as switch-type power lines.

5.2. Considerations During Variable Frequency Drive (VFD) Operation

When using JIE motors with a variable frequency drive, follow the connection instructions provided by the VFD manufacturer. Strictly adhere to the VFD's operating manual.

When JIE motors are operated with a variable frequency drive or similar devices, proper wiring measures must be taken to eliminate interference from switch equipment (such as the VFD). The motor windings must have interference suppression functionality and protect digital and logical programs. It is recommended to equip protective circuits (filter circuits) on the output line.

5.3. Environmental Conditions During Operation

Environmental Temperature and Humidity:

Optimal operation Temperature: The maximum air temperature should not exceed 40°C (104°F) and the minimum air temperature should not reach below -15°C (5°F). For humidity, the maximum percentage should not exceed 90% and during wet months, the lowest temperature should not be higher than 25°C (77°F).

Optimal Operation Altitude: Motor may function improperly if the altitude exceeds 1000 meters (3280 feet). Note: if the motor must be used at altitude higher than 1000 meters or under conditions where the air temperature is higher than 40°C. To calculate the loss in efficiency, follow the specified line charts below.

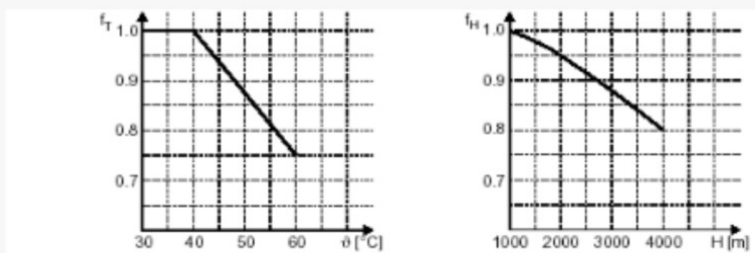

Figure 1

Figure 2

P_{nred} : Actual Output Power.

P_N : Rated Output Power.

f_r : Temperature coefficient, obtained from the curve in Figure 1.

f_H : Altitude coefficient, obtained from the curve in Figure 2.

Refer to the provided graph for allowable deviations in voltage and frequency from the rated values during motor operation.

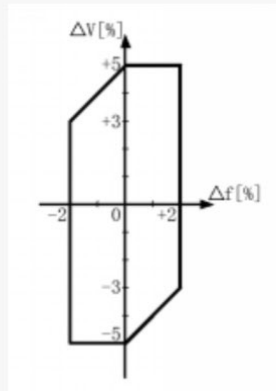

5.4. Motor Connection



When using electronic control devices, carefully follow the respective usage instructions/circuit diagrams.

5.4.1. Connecting the Motor via Junction Box

- Follow the provided circuit diagram.
- Check the conductor cross-section.
- Install the connecting terminals correctly.
- Tighten the joints and grounding screws with bolts.
- Inside the junction box: Ensure the winding connection and wires are properly fastened.

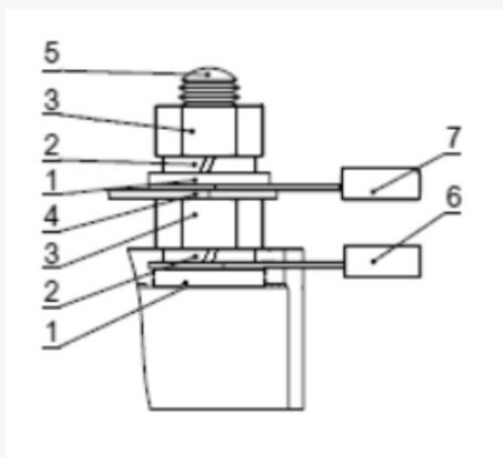

Junction Box Components:

1. Stop washer
2. Flat washer
3. Nut
4. Connector
5. Spring washer
6. Terminal
7. Customer power interface
8. Motor lead wires

5.4.2. Ground leads

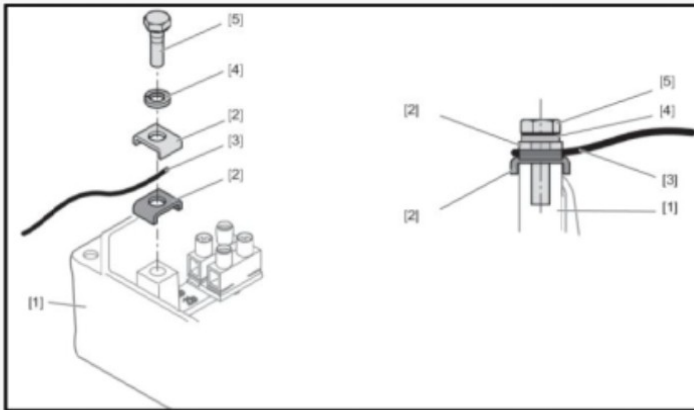

3~132 Engine bed

- [1] Terminal box
- [2] Binding post
- [3] Ground lead
- [4] Lock washer
- [5] Hexagon bolt

160~280 Engine bed

- [1] Hexagon bolt
- [2] Washer
- [3] Ground lead
- [4] Lock washer
- [5] Bolt
- [6] Terminal box

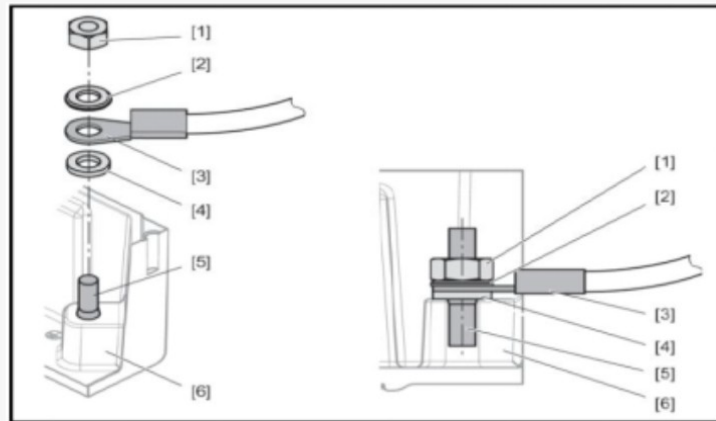

5.5 Junction box for motor connection

Engine seat number	Binding post	Hexagonal nut tightening torque	OT terminal specifications	Grounding terminal Φ
63	M4	1.6 Nm (14.2 Ib-in)	OT1-4	M4
71				
80				
90				
100				
112	M5	2.0Nm (17.7 Ib-in)	OT2.5-5	M5
132S				
132M/L	M6	3.0Nm (26.5 Ib-in)	OT4-6	M6
160				
180				
200	M8	6.0Nm (53.1 Ib-in)	OT10-8	M8
225				
250	M10	10Nm (88.5 Ib-in)	OT25-10	M10
280				

5.6. Wiring Method - Single-Speed Motor

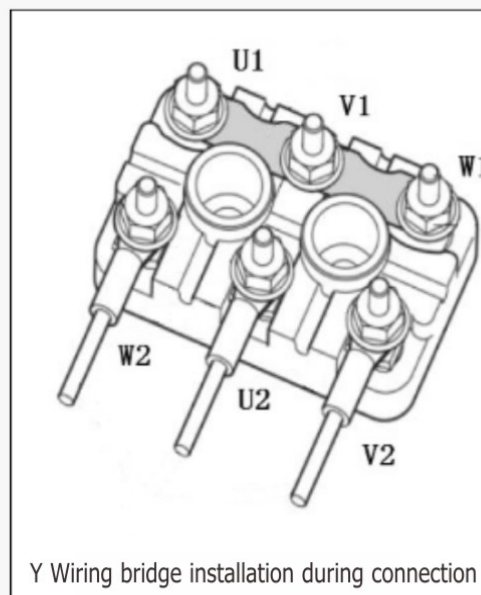
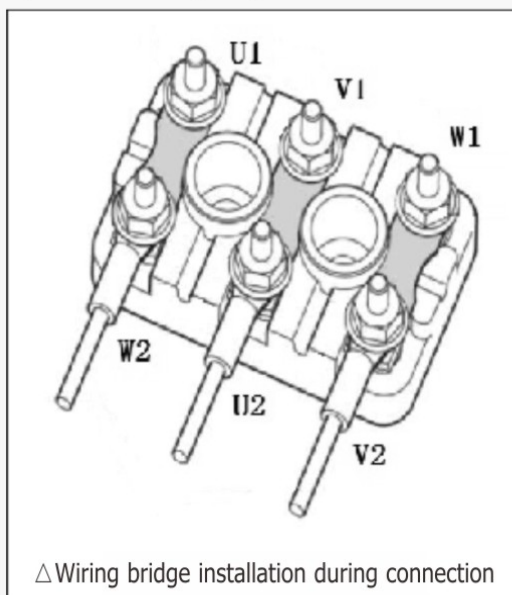

JIE
JDRIVE

280099000059

YY-Schaltung-low voltage **Y-Schaltung-high voltage**

Wiring bridge installation for YY/Y connection (9 lead wires).

JIE
JDRIVE

280099000060

△△-Schaltung-low voltage **△-Schaltung-high voltage**

△ △/△ Wiring bridge installation during connection (1 2 lead wires)

5.7. Wiring Method - Two-Speed Motor

5.7.1. Independent Two-Speed (8/2 poles)

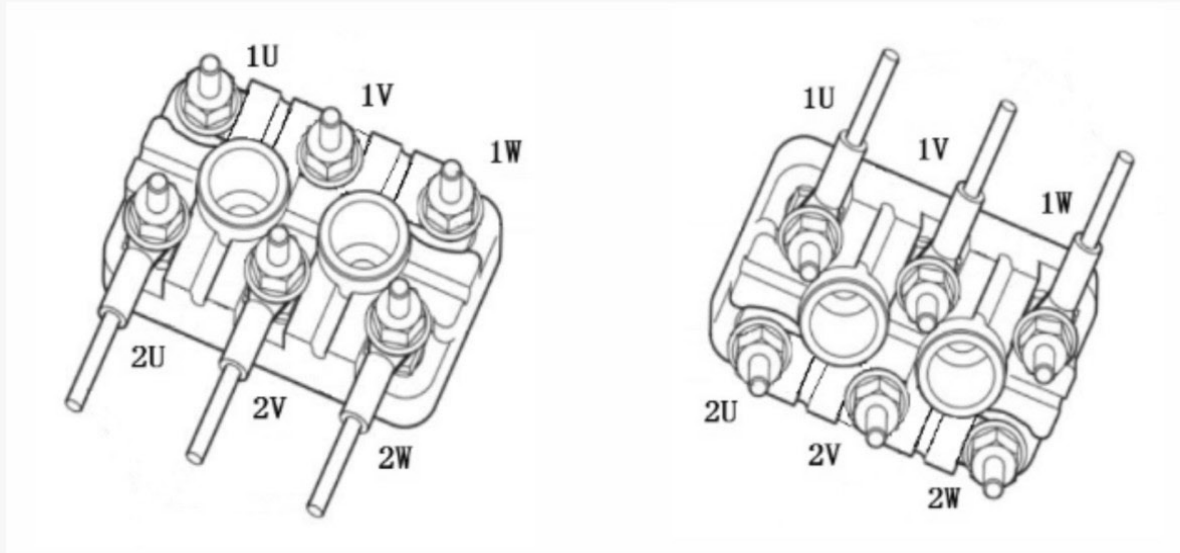

Wiring bridge installation at low speed

Wiring bridge installation at high speed

5.7.2. Variable-Pole Two-Speed - Wiring bridge installation for low-speed operation.

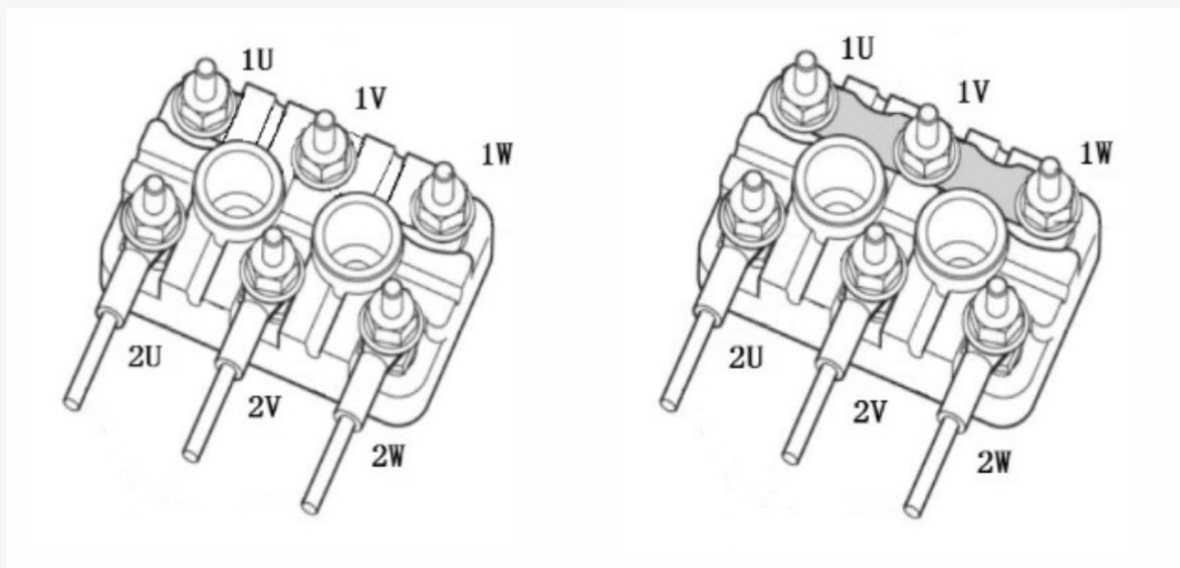

Wiring bridge installation at low speed

Wiring bridge installation at high speed

5.8. Wiring Method - Independent Fan

5.8.1. Single-Phase Asynchronous Independent Fan

Motor power supply

The nameplate corresponds to voltage

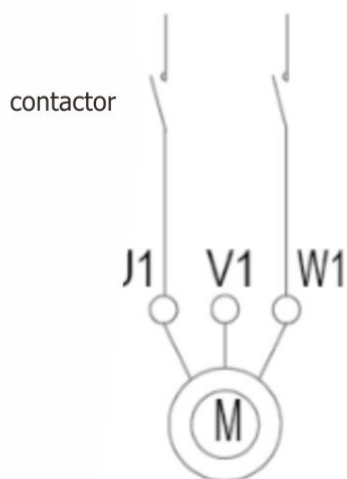

5.8.2. Three-Phase Asynchronous Independent Fan

Grid voltage

U="Y" corresponds to voltage

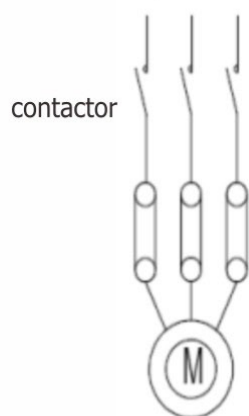

" Δ " Wiring diagram

Grid voltage

U="Y" corresponds to voltage

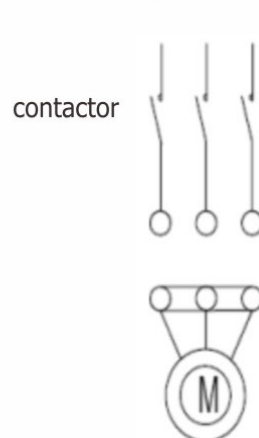

"Y" Wiring diagram

Brake power supply

5.9. Wiring Method - Brake

5.9.1. Motor Voltage 220 Δ V, 380YV Corresponding to Brake Voltage 220V and 380V Wiring

ID	Single speed motor voltage and wiring	Brake voltage	Brake connection	
			Ordinary braking	Rapid braking
1	220V Δ	220V	Motor power supply U=220V AC contactor Brake coil	Motor power supply U=220V AC contactor Brake coil
2		380V	Motor power supply U=220V AC contactor Brake coil	Brake power supply U=380V AC Brake coil
3	380V Y	220V	Motor power supply U=380V AC contactor Brake coil	Motor power supply U=380V AC contactor Brake coil
4		380V	Motor power supply U=380V AC contactor Brake coil	Motor power supply U=380V AC contactor Brake coil

5.9.2. Motor Voltage 380 Δ V, 660YV Corresponding to Brake Voltage 220V and 380V Wiring

ID	Single speed motor voltage and wiring	Brake voltage	Brake connection	
			Ordinary braking	Rapid braking
5	380V Δ	220V	Motor power supply U=380V AC contactor Brake coil	Brake power supply U=220V AC Brake coil
6		380V	Motor power supply U=380V AC contactor Brake coil	Motor power supply U=380V AC contactor Brake coil
7	660V Y	220V	Motor power supply U=660V AC contactor Brake coil	Brake power supply U=220V AC Brake coil
8		380V	Motor power supply U=660V AC contactor Brake coil	Motor power supply U=660V AC contactor Brake coil

5.9.3. Variable-Pole, Variable-Frequency Motor Brake Wiring

	Ordinary braking	Rapid braking
Variable pole speed regulating motor	<p>Motor power supply Brake power supply</p> <p>contactor</p> <p>Brake coil</p>	<p>Motor power supply Brake power supply</p> <p>contactor</p> <p>Brake coil</p>
Variable pole speed regulating motor	<p>Motor power supply Brake power supply</p> <p>contactor</p> <p>Brake coil</p>	<p>Motor power supply Brake power supply</p> <p>contactor</p> <p>Brake coil</p>

5.9.4. Connecting the Brake

When the brake is powered, it will release. After the power is cut, the brake will engage.



Warning!

Always maintain control of motor lifting equipment. Failure to do so can cause crushing, severe injury, or death.

- Pay close attention to the relevant regulations set by the NEC regarding phase loss protection and wiring/line conversion.

Rules for Conversion:

- Connect the brake strictly following the provided wiring diagram.
- Take into consideration connecting DC voltage and large current loads. If so, a special brake contactor must be used. Contact JIE for more instruction and details

If rapid braking is not specified, JIE company defaults to ordinary braking as the standard wiring method. If rapid braking is used, the customer must disconnect ordinary braking and wire according to the rapid braking method.

5.10. Auxiliary Equipment

5.10.1. Temperature Sensor TF



Damage to the temperature sensor may occur due to overheating. If this happens, the drive unit may become damaged. Do not apply a voltage greater than 30V to the temperature sensor TF.

The thermistor sensor complies with DIN 44082 standards.

Resistance measurement check (voltage of measuring instrument $\leq 2.5V$ or current $< 1mA$):

- Standard measurement values: 20 to 200 Ω , thermal resistance $> 4000\Omega$.

When using the thermistor sensor for temperature monitoring, the analysis function must be activated to maintain the sensor circuit in a safe insulation state. The thermal protection function must be activated in case of overheating.

5.10.2. Coil Thermostat TH

The standard connection of the thermostat is in series, and it will disconnect when the winding temperature exceeds the allowed range. The thermostat can be connected in the monitoring circuit of the drive unit.

	AC V	DC V	
voltageU [V]	250	60	24
Electric current ($\cos \phi = 1.0$) [A]	2.5	1.0	1.6
Electric current ($\cos \phi = 0.6$) [A]	1.6		
Maximum contact resistance 1 Ω DC5V/1mA			

5.10.3. Temperature Sensor PT100



Damage to the insulation material of the sensor and motor winding may occur if the PT100 circuit's current exceeds 4mA.

- Avoid a current greater than 4mA in the PT100 circuit.
- PT100 must be correctly connected to ensure accurate temperature sensor analysis. Pay attention to polarity.

The characteristic curve in the following figure shows the variation of resistance with the motor temperature change.

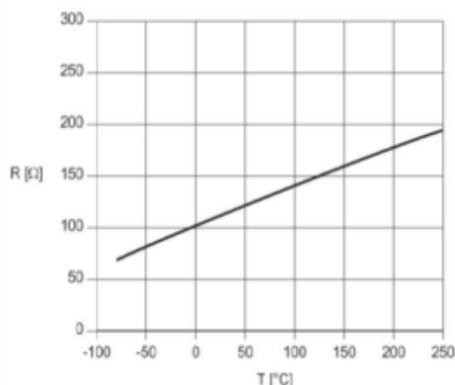

Technical Parameters:	Pt100
join	Red/White
Total Resistance (20~25 Ω)	107 Ω < R < 110 Ω
Detection Current	< 3mA

6. Brake Installation and Usage Instructions

6.1. Structure

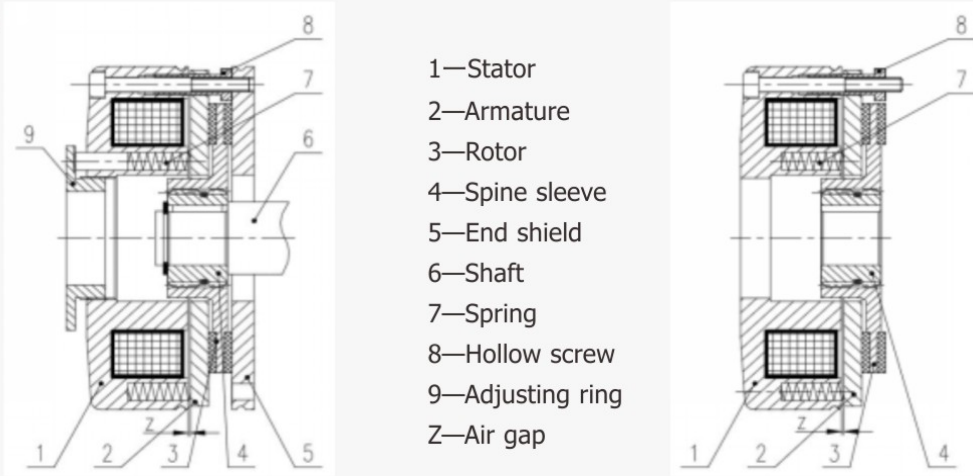

6.2. Installation Instructions

- The conductor must not have a damaged outer sheath to prevent damage to the circuit.
- Do not modify the positioning surfaces or the holes of the brake, doing so will affect the magnetic circuit
- When press-fitting on the shaft, avoid excessive force to prevent damage to the friction surface. Ensure that there are no burrs on the mounting hole and surface. Install the shaft with a spline sleeve and fix it with an axial collar.
- After the stator and armature components are installed, the air gap 'z' between them is crucial. Slight rotation should meet the specifications on the table. Contact JIE for the Z gap specifications for your model if needed.
- The protection level provided in Figure 1 is rated at IP23, Adding dust covers, dust caps, or shaft seals can achieve up to a IP54 rating.
- When assembling the handle lever and the handle ring arm, use a wrench to screw the thread to the end This will prevent any components from becoming loose.

6.3. Adjustment of Air Gap

Adjust the air gap between the stator and armature to the rated value 'z' using three handle screws and brake mounting screws (refer to Figure 2). Use a feeler gauge to ensure uniform gaps in all directions. Then lock the brake mounting screws. Adjust the three mounting screws individually as shown in the figure. After adjusting the air gap, tighten the mounting screws. If the gap is not within specifications, repeat the process.

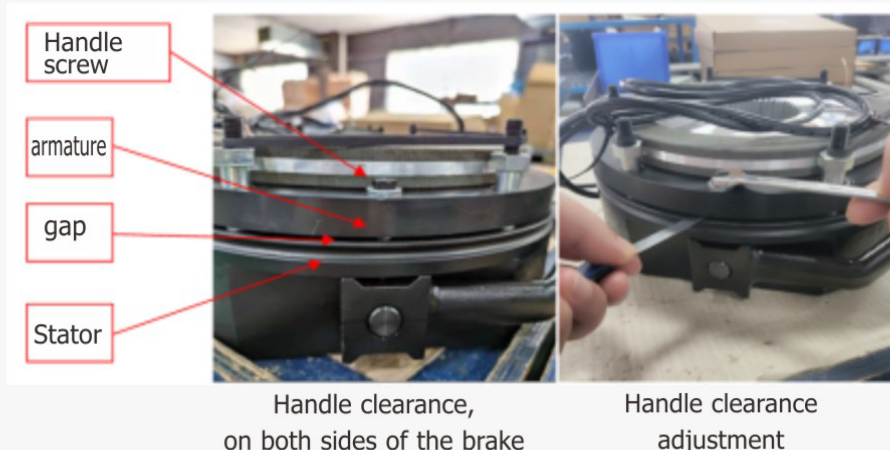

Re-adjustment of Air Gap:

The rated air gap 'z' may increase due to wear. To ensure sufficient braking torque, re-adjust the air gap before it reaches the maximum value. The air gap can be adjusted multiple times. When the thickness of the friction brake pad reaches the minimum allowed thickness (see specifications), replace the friction brake disc.

Exceeding the maximum air gap value can lead to brake release failure to release, burning of the friction brake pad, reduced braking force or holding force, and potentially serious accidents. Regularly check and re-adjust the air gap, ensuring the equipment is disconnected from the main power.

Handle Clearance Adjustment:

The gap between the manual release pads of the brake must be greater than the life gap of the brake. It is factory-adjusted, but if uneven, adjust using an open-end wrench.

Adjustment Method: The brake should be in the unlocked state. Adjust the handle screws (2 locations) with an open-end wrench to ensure the gap between the armature and stator. A thin feeler gauge corresponding to the lower limit of the handle gap should easily enter, while a thick feeler gauge corresponding to the upper limit should not.

Reference for Handle Clearance Range:

Engine seat number	Standard torque (Nm)	Rated clearance (mm)	Handle clearance (mm□)	Standard torque maximum air clearance	Minimum rotor thickness(mm)	The pretightening torque of the mounting screw (N .m)
63/71	3.5/5	0.15-0.3	0.8-0.9	0.5	4.7	2.5
80	10	0.15-0.3	0.8-0.9	0.5	6.4	5
90	20	0.15-0.3	0.8-0.9	0.5	8.1	8
100	40	0.25-0.4	1-1.1	0.75	8.4	8
112	60	0.25-0.4	1-1.1	0.75	8.7	20
132	80	0.25-0.4	1-1.1	0.75	8.8	20
160	200	0.35-0.5	1.2-1.3	1	11.4	20
180/200	300	0.35-0.5	1.2-1.3	1	12	40
225	400	0.45-0.6	2-2.1	1.25	15.5	40
250/280	1000	0.55-0.7		1.2	23	40

6.4. Brake Maintenance

a. If the motor is used in high humidity for sustained periods, prevent rust buildup or risk performance issues.

b. Do not directly touch the friction surface. Avoid oil stains to achieve maximum torque.

c. Generally suitable for an ambient temperature of -10°C to 40°C, excluding special user requirements.

d. Regularly check for normal switch operation, noise, abnormal heating, foreign objects or oil stains in friction and rotating parts, appropriate clearances, and normal excitation voltage.

Please note: For any issues arising from the use of JIE motors, we are committed to collaborating with our customers through a joint analysis to determine the cause and if it is a product quality failure. Please do not discard any failed components in order to qualify for replacement. However, JIE may refuse to accept responsibility for the following situations, regardless of the resulting issue.

a. ****Improper Disassembly and Installation:****The company shall not be held liable for damages resulting from the non-compliance with specified requirements during disassembly and installation, including the destruction of factory-thread riding seam paint.

b. ****Non-use of Torque Wrench:**** The company is not responsible for cases where a torque wrench is not utilized during screw installation, leading to excessive pre-tightening force, causing a reduction in the gap, generating noise, or resulting in unclean separation that causes friction-induced heat and damage to the brake.

c. ****Failure Due to Non-Company Components:****The company is not held liable for any brake failure caused by the malfunction of non-company components such as motors.

d. ****Exceeding Safe Operating Conditions:****The company is not accountable for failures resulting from overload, overspeed, overvoltage, excessive frequency of use, exceeding temperature and humidity limits, or operation beyond the specified safe range.

e. ****Improper Storage:****The company shall not be held responsible for failures due to improper storage, including exposure to moisture, rusting, or exceeding the storage period without proper inspection.

7. Debugging

7.1. Prerequisites for Debugging



The following safety precautions must be observed when the motor contains safety components.

- Functional safety component failure.
- Risk of severe injury or death.
- Operations related to functional safety components must be conducted by trained professionals.
- Operations related to functional safety components must strictly adhere to the instructions in the operation manual.

7.1.1. Before Putting into Operation

Before commencing debugging, ensure:

- The drive unit is not damaged and completely free of jams.
- Preparatory measures described in section 4.2 are taken after prolonged storage.
- All connections are completed according to specifications.
- The direction of the motor/reduction motor is correct.
- The motor rotates clockwise: W, U, V (single speed) correspond to L1, L2, L3.
- All protective covers are correctly installed.
- Activate all motor protection devices and adjust to the motor's rated current.
- There are no other potential hazards.

7.1.2. During the Debugging Operation

During the debugging process, confirm that:

- The motor operates normally, i.e.,
 - No overload.
 - No speed fluctuations.
 - No excessive noise.
 - No apparent oscillations, etc.
- The braking torque is suitable for the specific application.

For brake motors equipped with HR-type automatic return to the braking position and manual release, the handle must be removed after completing the debugging.

8. Inspection and Maintenance



Due to the risk of crushing equipment and lifting equipment becoming uncontrollable, leading to crush injuries, severe harm, or death:

- Ensure safety or lower the lifting gear (to prevent the danger of falling).
- Use a lower lifting gear to ensure safety
- Ensure the reliability and safety of the machine to prevent accidental contact.
- Disconnect the power supply to the all of the following components: motor, brake and forced air cooler (if applicable). ensure no accidental reconnection can occur before comencing work.
- Use only original spare or replacement parts according to the valid parts list



When the motor contains safety components, observe the following safety tips:
Functional safety component failure.
Risk of serious injury or death.

- Operations related to functional safety components must be carried out only by trained professionals.
- Operations related to functional safety components must strictly follow the instructions in the operation manual.



During operation, the surface temperature of the motor housing may become hot.
Use caution when touching the motor to prevent burns.

- Let the motor cool before resuming operation.



- The ambient temperature and the oil seal should never get below 0°C (32°F) during installation to prevent damage to the oil seal.

8.1. Inspection and Maintenance Cycle

Equipment/Component	Time Interval	Check/Maintenance Content
Brake	At least every 3000 operating hours (when used as a service brake) Depending on the load condition, every 2~4 years (when used as a holding brake)	- Check the brake: Measure the thickness of the brake disc friction plate, measure and adjust the working air gap, check the pressure plate, spline sleeve, and engagement, inspect the pressure ring, and suction of worn dust. Check the switch for electric shock, replace if necessary (e.g., when burned).
Motor	Every 10,000 operating hours	- Check the motor: Check the rolling bearing, replace if necessary, replace the oil seal, and clean the cooling air duct.
Driving Gear	Varied (depending on external factors)	- Repair or replace surface coating/antirust coating, check the air filter, clean if necessary.

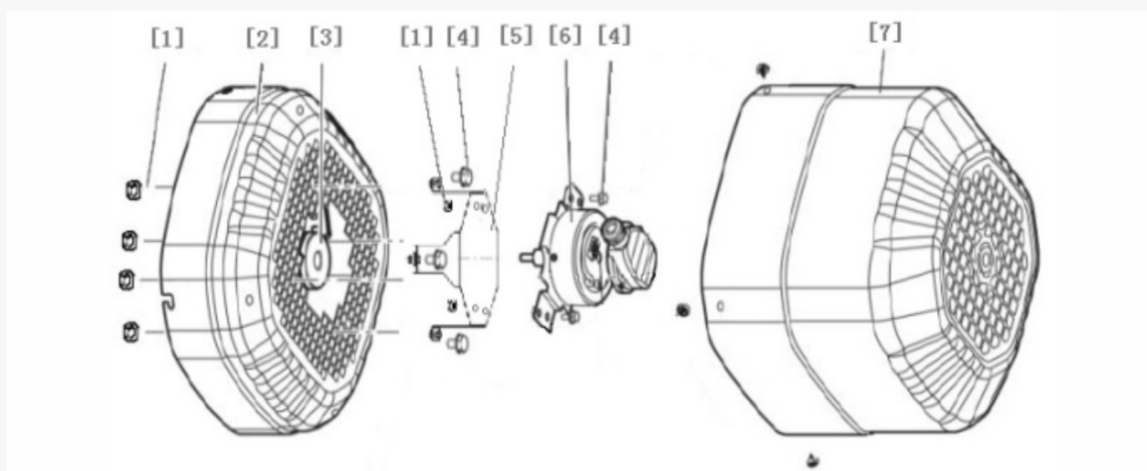

- [1] Hexagon nut
- [2] Fan Cowl
- [3] Tail end of shaft
- [4] Hexagon bolt
- [5] Support
- [6] Encoder
- [7] Shield

Note: The encoder in the drawing is a solid shaft encoder. If a hollow shaft encoder is selected, there is no bracket.

8.3. Motor Inspection Operation Steps

1. If there is a forced air blower and encoder, remove them.
2. Remove the fan cover and fan.
3. Motor Disassembly Steps:
 - For JD63~132 specifications: Unscrew the long screw at the lower end cover, and gently pry open the rear end cover, and then remove the stator from the flange bearing seat.
 - For JD160~225 specifications: Unscrew the hexagon bolt at the flange, take out the flange together with the rotor, and remove the rear end cover.
 - For JD250~280 specifications: Unscrew the hexagon bolt at the flange, unscrew the outer cover of the rear bearing, and take out the flange together with the rotor. Remove the rear end cover.
4. Visual inspection: Is there moisture or reducer oil in the stator cavity?
 - If not, proceed to step 7.
 - If there is moisture, continue with step 5.
 - If there is gear oil, please ask a professional repair or JIE to repair the motor.
5. If there is moisture in the stator cavity:
 - If it is a gear motor: Remove the motor from the gearbox.
 - If it is a motor without reducer: remove the A flange.
 - Remove the rotor.
6. Clean the winding, make it dry and conduct electrical inspection.
7. Replace the deep groove ball bearing with the allowable bearing (clearance is C3).
8. Replace the front and rear oil seals, and the oil seal lips need to be greased.
9. Re-seal the stator
 - Use non-drying sealing paste (applicable temperature -40°C~+180°C).
 - For motors of JD63~JD132 specifications, replace the sealing ring at the end cover.
10. Assemble Equipment/Component

9. Operation failure:

9.1. Motor Malfunctions

Breakdown	Possible reasons	Solution
The motor does not start.	Power line interruption	Check the wiring and correct it if necessary.
	Fuse blowing	Replace fuse
	Motor protection device has been activated.	Check whether the motor protection device is set correctly, and troubleshoot if necessary.
	Failure of motor contactor and failure in control system.	Check the control of motor contactor, and troubleshoot if necessary.
Motor does not start or it is difficult to start	The motor should be connected in delta, but is connected in star(Y)	Correct wiring mode
	The voltage or frequency seriously deviates from the rated value at least when starting.	Try to improve the power supply: check the section of the power cord.
The motor will not start when connected in star (Y). start only when connected in delta configuration.	There is not enough torque in star connection.	If the connection current of the star connection is not high enough, follow the triangle connection (under the nameplate voltage) to see if it meets the requirements. Otherwise, use a larger or special specification motor (consulting).
	There is an electric shock fault on the star-triangle connection switch.	Discharge fault
Wrong rotation direction	Motor wiring error	Swap two phase lines
The motor rumbles and consumes a lot of current.	Winding damage	The motor must be sent to a professional repair shop for repair.
	Rotor touch winding	
The fuse is blown or the motor protection device acts immediately.	Conductor short circuit	Discharge short circuit
	There is a short circuit in the motor.	Send it to a professional repair shop for troubleshooting.
	Wire connection error	Correct connection mode
	Motor short circuit to ground	Send it to a professional repair shop for troubleshooting.
When the load is applied, the rotational speed drops sharply.	Overload	Perform power measurement, use a higher power motor if necessary, or reduce the load.
	Voltage drop	Increase the cross section of the power cord
The motor heats up sharply (Measuring temperature)	Overload	Perform power measurement, use a higher power motor if necessary, or reduce the load.
	Insufficient heat dissipation	Correct the input quantity of cooling air, or make the cooling air ventilate smoothly, and install a strong cooling fan when necessary.
	Ambient temperature is too high.	Pay attention to the allowable temperature range
	The delta connection mode replaces the original star(Y) connection mode to connect the motors.	Correct wiring mode

The motor heats up sharply (Measuring temperature)	The power cord has poor contact (missing one phase).	Poor discharge contact
	Fuse blowing	Find and remove the cause (see above): replace the fuse.
	The deviation between the power supply voltage and the rated voltage of the motor is greater than 5%. Higher voltage is especially unfavorable for multipole low-speed motors, because when the voltage is higher, the idling current is close to the rated current under normal voltage.	Adjust the motor to match the supply voltage.
	Exceeding the rated working condition type (S1~S10, DIN57530), such as switching frequency is too high.	Adjust the rated operating condition type of the motor to match the required operating conditions: If necessary, seek professional assistance to determine the appropriate driving device.
Too much noise.	The ball bearing is distorted, contaminated or damaged.	Recalibrate the motor, check the ball bearing, add grease and replace it if necessary.
	Vibration of rotating parts	Discharge reason, discharge unbalanced difference when necessary.
	There are foreign objects in the cooling air channel.	Clean the cooling air channel.

9.2.malfunction in the brake

Brake does not engage.	Voltage error on the brake control device	Apply the correct voltage
	Brake control equipment failure	Replace the brake control device, check the internal resistance and insulation of the brake coil, and check the switchgear.
	If the maximum allowable working air gap is exceeded, the brake friction plate shall be worn.	Measure and adjust the working air gap
	There is a voltage drop > 10% on the power line.	Try to provide appropriate access voltage and check the cable section.
	Lack of heat dissipation and high brake temperature. Brake coil has turn-to-turn short circuit or grounding short circuit.	Replace the rectifier block according to the use situation. Replace the complete set of brakes and brake control devices (professional repair shop) Check the switchgear
	Rectifier module is damaged.	Replace rectifier block and brake coil.
The motor cannot be braked.	Incorrect working air gap Brake friction plate is worn. Brake torque error	Measure and adjust the working air gap Replace the whole set of friction plate backing plate. Change the braking torque: replace the brake.
	Handle or screw release is not unloaded.	Unload the load on the handle or unscrew the release screw.
Brake engagement delay	The brake is directly connected to the AC voltage terminal.	Connect DC and AC voltage terminals
There is noise within the brake range.	Meshing wear caused by sudden starting.	Check the brake design.
	Pulsating torque caused by incorrect adjustment of frequency converter	Adjust inverter parameters according to the operation manual.

9.3.Customer Service

If you require assistance from our Customer Service Department, please provide the following information:

Nameplate Data (Complete)

Type and Severity of the Fault

Time of Fault Occurrence and Associated Phenomena

Possible Causes

Environmental Conditions

Ambient Temperature

Air Humidity

Installation Altitude

Pollution Situation

Other Relevant Details



JIE JDRIVE

No.1, JIE Road, Hangzhou,
Zhejiang, China
Tel: +86 571 8299 1111
E-mail: jie@jie.com.cn
Web: www.jiedrive.com

JIE USA

493 Mission Street
Carol Stream, IL 60188 USA
Tel: +1 630 580 9986
E-mail: info@jie-drives.com
Web: www.jie-drives.com

JIE CANADA

130 Rue de l'Émissaire Drummondville,
Québec J2E 1S4 Canada
Tel: +1 819 850 9886
E-mail: info@jie-drives.com
Web: www.jie-drives.com